



INSTALLATION, OPERATION, & MAINTENANCE MANUAL



XML-300 300 LB MOTOCROSS LIFT

⚠ FOLLOW THIS MANUAL CAREFULLY TO ENSURE THE MACHINE WILL FUNCTION CORRECTLY AND PROVIDE MANY YEARS OF DEPENDABLE SERVICE. FAILURE TO FOLLOW THESE INSTRUCTIONS AND SAFETY WARNINGS MAY RESULT IN PERSONAL INJURY OR PROPERTY DAMAGE. USE OF STRAPS IS RECOMMENDED - SOLD SEPARATELY KEEP THIS MANUAL IN A SAFE DRY PLACE FOR FUTURE REFERENCE.



TITAN MARKETING, LLC

PO Box 7069 Greenwood, IN 46142
1.888.908-4826 FAX (317) 215.2770
www.titanlifts.com

To Our Valued Customers:

Thank you for purchasing a Titan Lifts® product. We hope this high quality equipment provides you with years of dependable service.

It is unfortunate that rare situations may occur with the products you purchase from Titan Lifts®. We value your business as well as the trust you have and need to maintain your relationship with us. Titan Lifts® carries liability coverage that may protect our customers if a situation does occur. However, as in all accidents there must be proof of liability for a claim to be made. Our insurance company requires the following procedures be observed in order to consider a claim:

- A. The claimant must contact the Titan Lifts® distributor immediately with the facts of the situation.
- B. If any equipment is damaged, including vehicles or shop equipment, Titan Lifts® must be given the opportunity to send an impartial representative to the site for proper assessment of the situation.
- C. The Vehicle cannot be moved until either an impartial representative has reviewed the accident or clear and precise pictures are taken that reflect all the pertinent information for an impartial representative to be able to access the information from a distance. Titan Lifts® or its representatives must approve the pictures before anything can be moved.
- D. If any potential liability is determined on behalf of Titan Lifts®, two estimates must be submitted for damages to be reimbursed.

It is imperative that the claimant complies with these procedures, because without proper assessment of the situation a claim will be denied.

ARBITRATION NOTICE

The installation or use of this equipment shall constitute an acknowledgement that the user agrees to resolve any and all disputes or claims of any kind whatsoever, which relate in any way to the equipment, by way of binding arbitration, not litigation. No suit or legal action may be filed in any state or federal court. Any arbitration shall be governed by the Federal Arbitration Act, and administered by the American Mediation Association, Indianapolis Indiana. The maximum amount that an arbitrator may award and all damages shall not exceed the retail value of this equipment.

WARRANTY NOTICE

This equipment must be installed by a "Professional Installer" assembled and used in the manner according to the documentation provided to be covered by warranty.

Damaged or missing components must be reported within 72 hours of receipt to your freight carrier and to the distributor. Claims must be filed to cover cost.

If you have any questions or if we can be of any further assistance, please don't hesitate to contact a Titan Lifts® representative at 1-888-908-4826. Thank you for the opportunity to continue to serve your lift equipment needs.

INSTRUCTIONS

 **WARNING:** READ ENTIRE MANUAL AND COMPLY WITH ALL SAFETY AND SERVICE PRECAUTIONS. DEATH, PERSONAL INJURY AND/OR PROPERTY DAMAGE MAY OCCUR IF INSTRUCTIONS ARE NOT FOLLOWED CAREFULLY.

UNPACKING AND SET-UP

1. Carefully unpack the lift making sure that all of the parts have been included.
2. Make sure to use the lift on a clean, smooth solid surface.
3. Before lifting, make sure the bike is firmly secured to the lifting deck plate using the threaded knobs, large washers, J-hooks, and U-bolts.
4. Load must be firmly positioned and secured to the deck plate at all times.

OPERATION & MAINTENANCE

1. Check for any air in the hydraulic system. Open the release valve and rapidly pump the foot pedal at least 15 times to purge away any air from the system.
2. To raise the deck plate, turn the release valve clockwise until tight, and then manually pump the foot pedal until you reach the desired working height.
3. **IMPORTANT:** Once the deck plate has been raised, engage the locking bar and slowly lower the deck plate by turning the release valve counterclockwise until it rests upon the locking bar. This will prevent accidental lowering of the platform.
4. When work is complete, check under the lift and motorcycle to ensure that there are no obstructions and that it is safe to lower the unit.
5. Tighten the release valve by turning it clockwise until tight, and then raise the lift to release pressure off the locking bar. Remove the locking bar, and then slowly turn the release valve counterclockwise to gently lower the lift into the lowest position.
6. All moving parts have been lubricated at the factory and should be re-lubricated before the first use and at least once every six months to prevent damage.
7. Lightly oil cylinder rod at least once every six months, or when it becomes dry.
8. Do not use this product if worn or damaged. Examine lift for structural cracks, bends, or other signs of damage prior to each use to ensure safe proper working condition.
9. Keep the lift clean, dry, and well maintained to extend longevity of the product.
10. When not in use, the lift must be stored in the lowest position, in a dry location.

SAFETY PRECAUTIONS

1. Load should not exceed rated capacity for this lift – 300lbs
2. Only trained people should operate the lift.
3. Indoor use recommended.
4. Do not move the lift while loaded.
5. Keep hands, tools, and other extremities from any moving parts.
6. Maintain a safe working environment. The work area should be clean, dry, clutter free, and sufficiently lit.
7. Wear proper safety attire. Do not wear loose fitting clothing while operating lift, long hair and sleeves should be secured.
8. Keep children and bystanders away from work area. Do not let children operate or play on lift.
9. Do not use if under the influence of drugs or alcohol. Operator must be alert at all times when using heavy lift equipment.
10. Never operate the lift with someone on it.
11. Use this lift only for the work it is intended. Do not use this product for an application for which it was not designated. Misuse can lead to personal injury and/or property damage.

WARNING

The warnings, precautions and instructions in this manual cannot cover all possible conditions and situations that may occur. The operator must understand that the operator must supply common sense and examine caution factors when using this product to determine safety in all circumstances being used.

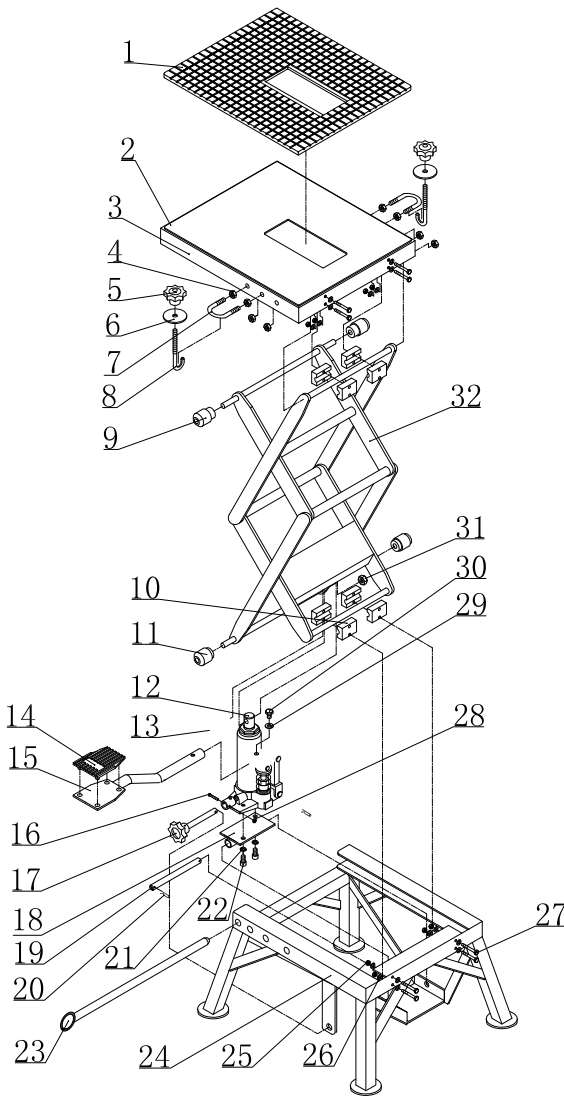

NO.	DESCRIPTION	QTY
1	RUBBER PAD	1
2	STEEL PLATE	1
3	UPPER FRAME	1
4	NUU M8	8
5	THREADED KNOB	2
6	WASHER	2
7	U-BOLT	2
8	J-HOOK	2
9	UPPER ROLLER	2
10	FIXING BLOCK	8
11	LOWER ROLLER	2
12	PUMP	1
13	BOLT M10*55	1
14	FOOT PEDAL PAD	1
15	FOOT PEDAL	1
16	BOLT M4X25	1
17	RELEASE VALVE	1
18	CONNECTING PLATE	1
19	CONNECTING PIN	1
20	R-PIN	2
21	LOCK WASHER 8	2
22	BOLT M8X16	2
23	LOCKING BAR	1
24	BASE FRAME	1
25	NUT M5	8
26	WASHER 5	16
27	BOLT M5X40	8
28	NUT M4	1
29	WASHER Ø8	1
30	BOLT M8X12	1
31	NUT M10	1
32	LIFTING ARM ASSY	1



TITAN MARKETING, LLC

PO Box 7069 Greenwood, IN 46142
 1.888.908-4826 FAX (317) 215.2770
www.titanlifts.com

Copyright © 2010 by Titan Marketing, LLC. All rights reserved. No portion of this manual or any artwork contained herein may be reproduced in any shape or form without the express consent of Titan Marketing, LLC. Diagrams within this manual may not be drawn proportionally. Due to continuing improvements, actual product may differ slightly from the product described herein. Tools required for assembly and service may not be included.