

TIE-DOWN ARM EXTENSION KIT

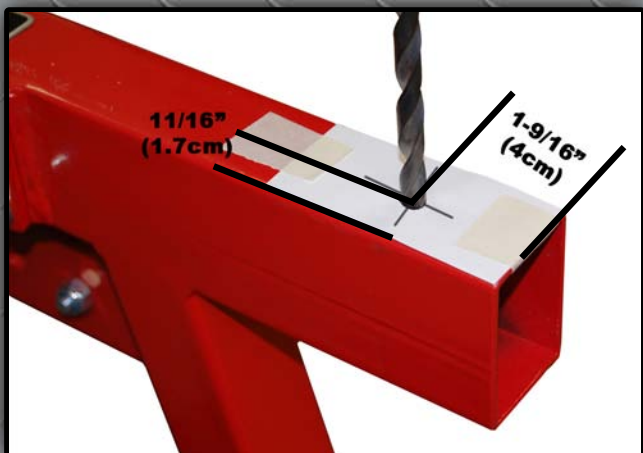

1. Remove the two front non-slip rubber feet from the base. If holes already exist in the frame, move on to step five.



2. If there are no holes in the frame, on the front and back side of the front leg of the frame measure $11/16"$ (1.7 cm) from the top and $1-9/16"$ (4 cm) from the end and mark the location.



3. It is recommended that you use a center punch prior to drilling. Use a $5/16"$ (8mm) metal drill bit to drill out the marked locations. The holes on the front should be directly across from those on the back.

TIE-DOWN ARM EXTENSION KIT

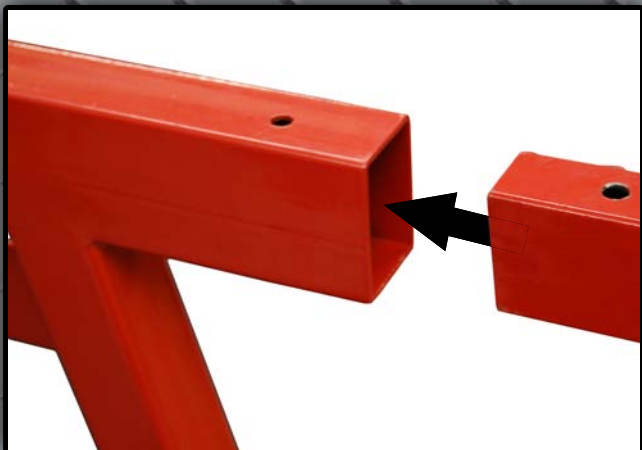

4. Clear all shavings from the area before inserting leg extensions.



5. Insert leg extensions with the eye bolt holes facing upwards and secure them in place by using the quick release retaining pins.

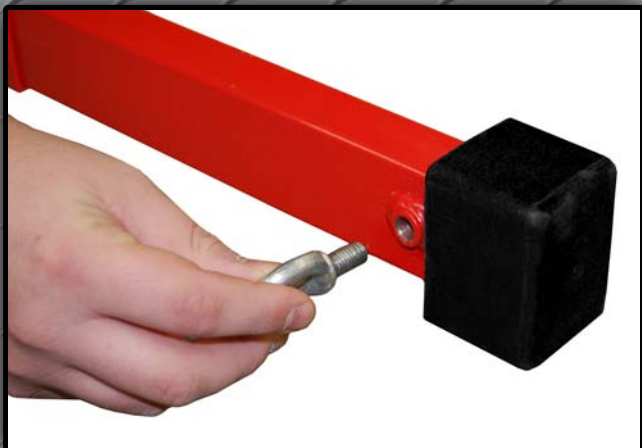

6. Insert the eye bolts securely into the provided holes.