

# Titan Roller Stand

## RS-500 Motorcycle Wheel Stand



**Front Wheel**



**Rear Wheel**

- Rotate your tire without lifting it off the ground
- Low profile for easy on and off access
- Powder coated, sealed bearings and non-slip backing
- Assists in cleaning your front and rear wheels
- Great for chain maintenance and polishing
- 500 lb. Capacity



**888.908.4826** [www.titanlifts.com](http://www.titanlifts.com)

**⚠ WARNING:** READ ENTIRE MANUAL AND COMPLY WITH ALL SAFETY AND SERVICE PRECAUTIONS. DEATH, PERSONAL INJURY AND / OR PROPERTY DAMAGE MAY OCCUR IF INSTRUCTIONS ARE NOT FOLLOWED CAREFULLY.

## SAFETY PRECAUTIONS

The Titan Roller Stand is meant for use on a flat and level surface that is not slick or finished. Before using this equipment, make sure that your floor space is flat and even. **DO NOT** use the Roller Stand on sloping uneven surfaces or finished floors.

Wheel rotation should be by hand only. The Titan Roller Stand is designed for the manual rotation of tires and is not meant to be used with the engine running or with the vehicle in gear. Always check that the vehicle is in neutral and that the engine is off before using the Titan Roller Stand.

Before use, make sure that the vehicle is completely supported and stable.

## OPERATION & MAINTENANCE

1. Place the Titan Roller Stand approximately 8 inches in front of (for front tire maintenance) or behind (for rear tire maintenance) the tire, making sure that the ramp is facing towards the vehicle.
2. Make sure that the rollers are perpendicular to the vehicle and the tire that is being put upon it.
3. Manually roll the vehicle onto the Titan Roller Stand so that the tire rests between the two rollers.
4. Secure the vehicle in place. Use of a center stand, wheel chock, elevated kickstand or other support systems may be necessary.
5. Rotate the wheel by hand. Be aware if the wheel moves to one side of the stand. This can be corrected by changing the direction that the wheel is being rotated.

To clean the Titan Roller Stand, use a clean dry towel to wipe off any dirt and oil. **DO NOT** immerse the unit in water or solvents.

### ⚠ WARNING ⚠

The warnings, precautions and instructions in this manual cannot cover all possible conditions and situations that may occur. The operator must understand that the operator must supply common sense and examine caution factors when using this product to determine safety in all circumstances being used.

NO.	DESCRIPTION	QTY
01	SIDE BEAM	2
02	WASHER	8
03	BEARING	4
04	HOLD DOWN	1
05	SCREW	4
06	RUBBER PAD	6
07	PIN	2
08	ROLLER	2
09	LEAD PLATE	1
10	O-RING	1

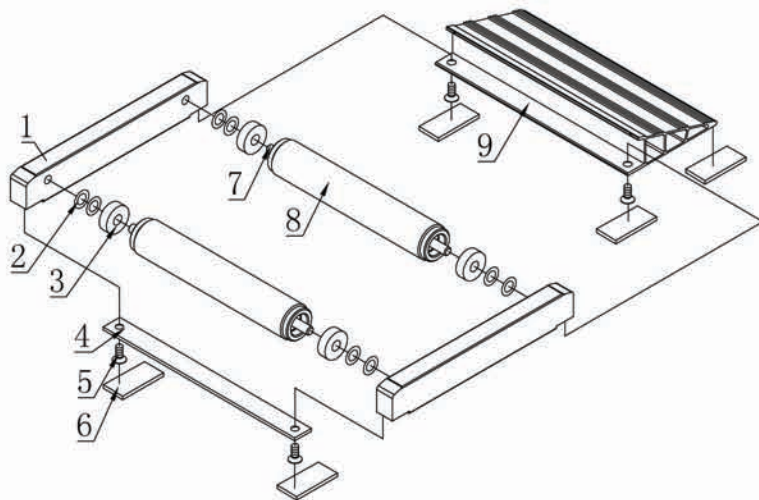

8 3765444322 4