



INSTALLATION, OPERATION & MAINTENANCE MANUAL



MODEL:

**MRL-6000
6,000 LB CAPACITY SCISSOR LIFT**

⚠ FOLLOW THIS MANUAL CAREFULLY TO ENSURE THE EQUIPMENT WILL FUNCTION CORRECTLY AND PROVIDE MANY YEARS OF DEPENDABLE SERVICE. FAILURE TO FOLLOW THESE INSTRUCTIONS AND SAFETY WARNINGS MAY RESULT IN PERSONAL INJURY OR PROPERTY DAMAGE. KEEP THIS MANUAL IN A SAFE DRY PLACE FOR FUTURE REFERENCE.



TITAN MARKETING, LLC

PO Box 7069 Greenwood, IN 46142
1.888.908-4826 FAX (317) 215.2770
www.titanlifts.com

To Our Valued Customers:

Thank you for purchasing a Titan Lifts® product. We hope this high quality equipment provides you with years of dependable service.

It is unfortunate that rare situations may occur with the products you purchase from Titan Lifts®. We value your business as well as the trust you have and need to maintain your relationship with us. Titan Lifts® carries liability coverage that may protect our customers if a situation does occur. However, as in all accidents there must be proof of liability for a claim to be made. Our insurance company requires the following procedures be observed in order to consider a claim:

- A. The claimant must contact the Titan Lifts® distributor immediately with the facts of the situation.
- B. If any equipment is damaged, including vehicles or shop equipment, Titan Lifts® must be given the opportunity to send an impartial representative to the site for proper assessment of the situation.
- C. The Vehicle cannot be moved until either an impartial representative has reviewed the accident or clear and precise pictures are taken that reflect all the pertinent information for an impartial representative to be able to access the information from a distance. Titan Lifts® or its representatives must approve the pictures before anything can be moved.
- D. If any potential liability is determined on behalf of Titan Lifts®, two estimates must be submitted for damages to be reimbursed.

It is imperative that the claimant complies with these procedures, because without proper assessment of the situation a claim will be denied.

ARBITRATION NOTICE

The installation or use of this equipment shall constitute an acknowledgement that the user agrees to resolve any and all disputes or claims of any kind whatsoever, which relate in any way to the equipment, by way of binding arbitration, not litigation. No suit or legal action may be filed in any state or federal court. Any arbitration shall be governed by the Federal Arbitration Act, and administered by the American Mediation Association, Indianapolis Indiana. The maximum amount that an arbitrator may award and all damages shall not exceed the retail value of this equipment.

WARRANTY NOTICE

This equipment must be assembled and used in the manner according to the documentation provided to be covered by warranty.

Damaged or missing components must be reported within 72 hours of receipt to your freight carrier and to the distributor. Claims must be filed to cover cost.

If you have any questions or if we can be of any further assistance, please don't hesitate to contact a Titan Lifts® representative at 1-888-908-4826. Thank you for the opportunity to continue to serve your lift equipment needs.

CONTENTS

1-SAFETY	1
1.1 INTRODUCTION.....	1
1.2 SAFETY INSTRUCTIONS FOR COMMISSIONING.....	1
1.3 SAFETY INSTRUCTIONS FOR OPERATION.....	1
1.4 SAFETY INSTRUCTIONS FOR MAINTENANCE	3
1.5 RISKS.....	3
2-UNPACKING & SETUP	4
2.1 DELIVERY AND CHECK OF PACKAGES	4
3-SPECIFICATIONS	5
4-FLOOR REQUIREMENTS	6
4.1 SELECTING THE SITE AREA	6
4.2 FLOOR REQUIREMENTS	6
5-INSTALLATION INSTRUCTIONS	7
5.1 MOUNT HYDRAULIC POWER UNIT/CONNECT HOSE ASSEMBLY	7
5.2 LIFTING THE UNIT TO ATTACH THE LIFTING PLATES AND SADDLES	7
5.3 LIFTING PLATES, ADAPTERS & RUBBER SADDLE ATTACHMENT.....	7
5.4 ELECTRICAL CONNECTIONS.....	8
6-OPERATION INSTRUCTIONS	8
6.1 DEFECTS / MALFUNCTIONS.....	8
6.2 CONTROLS.....	8
6.2.1 UP CONTROL.....	8
6.2.2 SAFETY LOCK CONTROL.....	9
6.2.3 LOWERING CONTROL	9
6.3 OPERATION.....	9
7-MAINTENANCE	11
7.1 MAINTENANCE SCHEDULE	11
7.1.1 DAILY	11
7.1.2 MONTHLY.....	11
7.1.3 BIMONTHLY	11
7.1.4 YEARLY	11
7.1.5 EVERY OTHER YEAR.....	11
7.2 MAINTENANCE BY OPERATOR	12
7.2.1 HYDRAULIC SYSTEM (FIG. 5)	12
7.2.2 GREASING POINTS.....	12
7.2.3 OPERATION AND WEAR CHECKS	13
7.2.4 LIFT STABILITY	13
7.3 CLEANING	13
8-TROUBLESHOOTING	14
9-DIAGRAMS	15
FIG. 1 - EXPLODED VIEW	15

INSTRUCTIONS

1-SAFETY

1.1 INTRODUCTION

 **WARNING:** READ ENTIRE MANUAL AND COMPLY WITH ALL SAFETY AND SERVICE PRECAUTIONS. DEATH, PERSONAL INJURY AND / OR PROPERTY DAMAGE MAY OCCUR IF INSTRUCTIONS ARE NOT FOLLOWED CAREFULLY.

Personal injury and property damage incurred due to non-compliance with these safety instructions are not covered by the product liability regulations.

SYMBOLS

 **FAILURE TO COMPLY WITH INSTRUCTIONS COULD RESULT IN PERSONAL INJURY.**

 **FAILURE TO COMPLY WITH INSTRUCTIONS COULD RESULT IN PROPERTY DAMAGE.**

 **IMPORTANT INFORMATION**

1.2 SAFETY INSTRUCTIONS FOR COMMISSIONING

- The lift may be installed and commissioned by authorized service personnel only.
- The standard lift version may not be installed and commissioned in the vicinity of explosives or flammable liquids, outdoors or in moist rooms (e.g. car wash).

1.3 SAFETY INSTRUCTIONS FOR OPERATION

- Read this entire manual.
- Load should not exceed rated capacity for this lift –6,000 lbs.
- Only trained authorized personnel over the age of 18 years should operate the lift.
- Indoor use recommended.
- Never use the lift to raise one end or one side of vehicle.
- If an extension cord is necessary, a cord with a current rating equal to or more than that of the equipment should be used. Cords rated for less current than the equipment may overheat.

- Maintain a safe working environment. The work area should be clean, dry, clutter free, and sufficiently lit.
- Vehicle doors should be closed during the raising and lowering cycles.
- Closely watch the vehicle and lift during the raising and lowering cycles.
- Do not operate the lift in explosive atmospheres, such as in the presence of flammable liquids, gases, or dust. Power equipment can create sparks which may ignite flammables.
- Keep hands, tools, and other extremities from under carriage and moving parts.
- Never operate this lift with someone on it.
- Do not allow anyone on the lift or inside a raised vehicle.
- Keep children and bystanders away from work area. Do not let children operate or play on lift.
- Wear proper safety attire. Do not wear loose fitting clothing while operating lift. Long hair, jewelry and sleeves should be secured.
- Never leave the lift unattended while under a load.
- Do not operate this lift if under the influence of drugs, alcohol, or medication. Operator must be alert at all times when using heavy lift equipment.
- Comply with all applicable accident prevention regulations.
- Only use the vehicle manufacturer's recommended lifting points.
- After positioning the vehicle, apply the parking brake.
- Use caution when removing or installing heavy vehicle components which may result in center-of-gravity displacement.
- Use this lift only for the work it is intended. Do not use this product for an application for which it was not designed. Misuse can lead to personal injury and/or property damage.

 **WARNING:** Prior to completely raising the vehicle, raise the vehicle 6" off the ground and check the adapter pads for solid contact by performing the "BUMPER TEST". Walk around the back of the vehicle and push up and down on the bumper. The vehicle will rock, but should not at any time lose contact with the pads. If the vehicle is bouncing off the pads or feels at all unstable, you should lower it back to the ground and reposition the pads to balance the load. Repeat this process until the vehicle is completely stable.

 **WARNING:** Use this lift only in well ventilated areas. Carbon monoxide exhausted from running vehicle engines is a colorless, odorless fume that, if inhaled, can cause serious personal injury or death.

 **WARNING:** People with pacemakers should consult their physician(s) before using this product. Operation of electrical equipment in close proximity to a heart pacemaker could cause interference or failure of the pacemaker.

 **WARNING:** This product contains or produces a chemical known to the State of California to cause cancer and birth defects (or other reproductive harm). (California Health & Safety Code 25249.5 et seq.)

1.4 SAFETY INSTRUCTIONS FOR MAINTENANCE

- Maintenance or repair work should be done by authorized service personnel only.
- Work on the electrical equipment should be done by certified licensed electricians only.
- Ensure that ecologically harmful substances are disposed of in accordance with the appropriate regulations.
- To prevent the risk of damage, do not use high pressure / steam jet cleaners or caustic cleaning agents.
- Do not replace or override the safety devices.

1.5 RISKS



WARNING: Risks the personnel could encounter, due to an improper use of the lift, are described in this section.

CRUSHING RISK

During lowering of the equipment and vehicles, personnel must not be within the area covered by the lowering trajectory. The operator must be sure no one is in danger before operating the lift. Stay clear of the lift when lowering or raising vehicles. Keep hands and feet away from moving parts and especially points that could pinch. Keep your feet clear of the lift when raising and lowering vehicles.

BUMPING RISK

When the lift is stopped at relatively low working height, the risk of bumping against projecting parts increases. Always be aware of your surroundings and avoid bumping your head or body on the lift or the vehicle.

RISK OF THE VEHICLE FALLING FROM THE LIFT

Risk of the vehicle falling from the lift is increased: when the vehicle is improperly placed on the platforms, when the vehicle's weight or physical dimensions exceed the rated capacity of the lift, or when there is excessive movement of the vehicle while on the lift. If vehicle appears to begin falling, exit the area as quickly as possible to avoid injury. Always position vehicle with the center of gravity midway between the adapters. Adding or removing parts of a vehicle on the lift will alter the weight displacement on the lift. Therefore, use of auxiliary safety stands in the front and back of the vehicle is recommended. Never override the manufactured lift controls. Always use height adapter pads when possible to ensure proper contact. Only authorized personnel should be allowed in the lift area and the lift should only be operated by authorized and trained personnel.

2-UNPACKING & SETUP

Only skilled personnel who are familiar with the lift and this manual shall be allowed to carry out, lifting, handling, transport and unpacking operations.

2.1 DELIVERY AND CHECK OF PACKAGES

When the lift is delivered, carefully unpack the lift making sure all the parts have been included. Check for possible damages due to transport and storage; verify that what is specified in the confirmation of order is included. In case of damage in transit, the customer must immediately inform the carrier of the problem.

Remove the lift and all parts from delivery pallet and place on a clean, solid, flat surface. Packages must be opened paying attention not to cause damage to people (keep a safe distance when opening straps) and parts of the lift (be careful the objects do not drop from the package when opening).



LIFT AND HANDLE ONLY ONE PACKAGE AT A TIME

3-SPECIFICATIONS

i **IMPORTANT: THE PROPERTIES INDICATED APPLY TO LIFTS RUNNING AT OPERATING TEMPERATURE.**

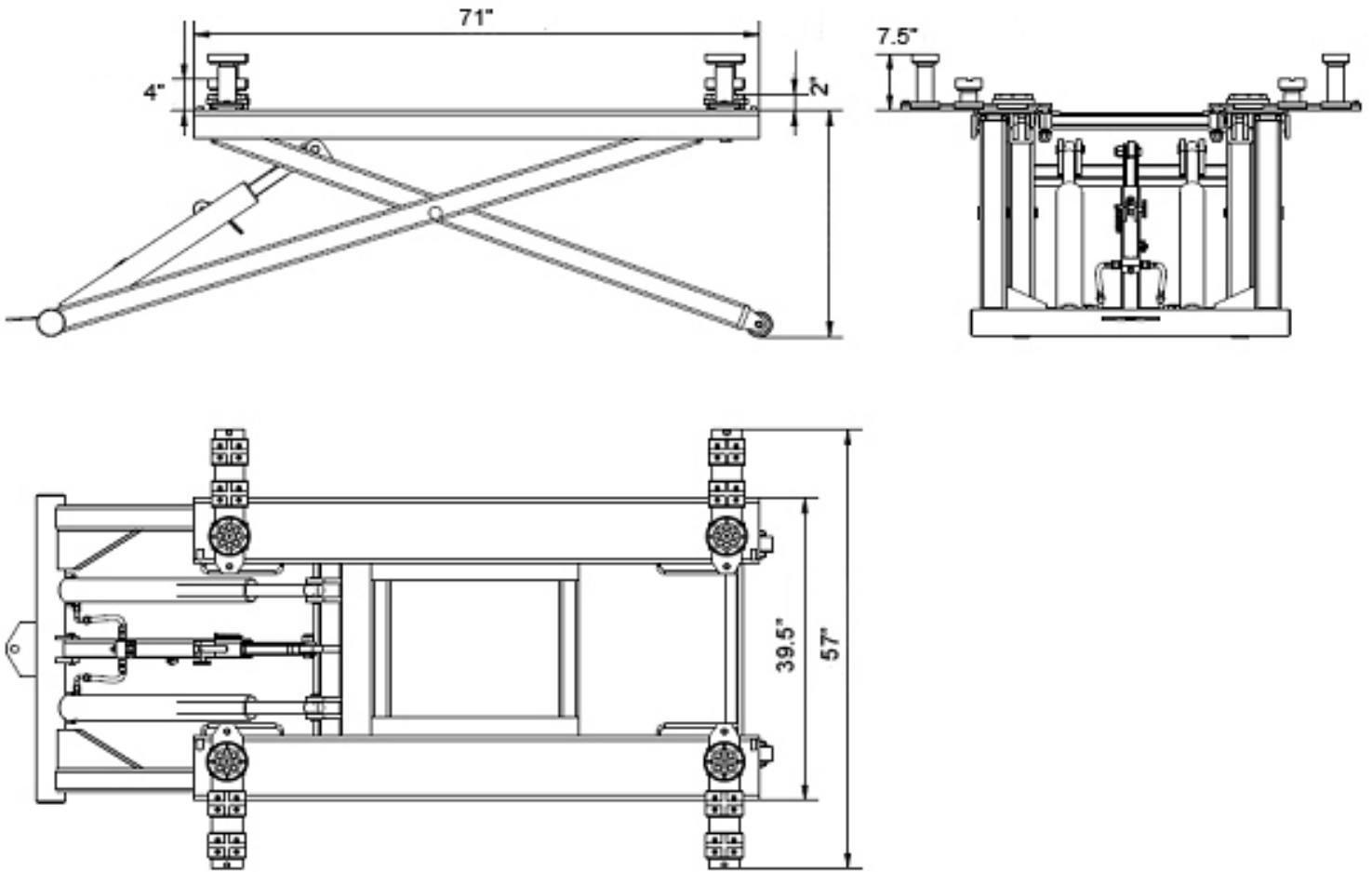

SPECIFICATIONS	MRL-6000
Load capacity	6,000 lbs
Raising / Lowering time	Approx. 40sec.
Minimum height	5-1/2"
Maximum lifting height	60"
Operating temperature	41-131°F
Net weight	1,052 lbs
Motor power	2.2KW
Length	100"
Width Min/Max	39-1/2" / 57"
Power supply	110V-120V,60Hz, 3HP/ Single Phase, 3 prong power plug, 20 AMP

i **IMPORTANT: SPECIFICATIONS ARE SUBJECT TO CHANGE WITHOUT NOTICE.**

4-FLOOR REQUIREMENTS

These notes are for your guidance prior to installation.

4.1 SELECTING THE SITE AREA

Make sure that adequate space and height is available.

4.2 FLOOR REQUIREMENTS

Do not use the lift on any asphalt surface. Make sure the lift is used on a dry, oil/grease free, flat level CONCRETE surface capable of supporting the weight of the lift, the vehicle being lifted, and any additional tools and equipment. The concrete floor surface should have a minimum thickness of 4". The concrete must have a minimum strength of 3,000 PSI and should be aged at least 30 days prior to use. Do not use the lift on concrete expansion seams or on cracked, defective concrete. **NOTE: Due to the function of this lift, the rollers may mar the finish on a concrete floor, especially when under load.**



WARNING: SPECIFICATIONS OF CONCRETE MUST BE ADHERED TO. FAILURE TO DO SO COULD CAUSE LIFT FAILURE RESULTING IN PERSONAL INJURY OR DEATH. THE FLOOR SHOULD BE A REINFORCED CONCRETE SLAB NOT LESS THAN 4" (101.6MM) THICK WITH THE COMPRESSIVE STRENGTH OF THE CONCRETE NO LESS THAN 3,000 PSI (20.68MPA).



DANGER: FOR CORRECT INSTALLATION OF THE LIFT, THE FLOOR MUST BE FLAT AND LEVEL. CHECK WITH STRAIGHT EDGE AND LEVEL. IF A FLOOR IS OF QUESTIONABLE SLOPE, CONSIDER A SURVEY OF THE SITE AND/OR THE POSSIBILITY OF POURING A NEW LEVEL CONCRETE SLAB.



IMPORTANT: NEW CONCRETE MUST BE ADEQUATELY CURED AT LEAST 30 DAYS MINIMUM. NO LIABILITY FOR ANY DAMAGES WILL BE ACCEPTED SHOULD YOU INSTALL THE LIFT ON AN UNSUITABLE FLOOR.

5-INSTALLATION INSTRUCTIONS



IMPORTANT: THE HYDRAULIC HOSES HAVE BEEN PRE-INSTALLED FOR YOUR CONVENIENCE. BE CAREFUL NOT TO CUT THE HYDRAULIC HOSES DURING THE INSTALLATION PROCESS.

5.1 MOUNT HYDRAULIC POWER UNIT/CONNECT HOSE ASSEMBLY

1. Attach the tow handle(1) to the pedestal(6) using the four(4) supplied attached bolts, washers, and nuts.
2. Attach the hydraulic unit to the pedestal using the four(4) supplied attached bolts, washers, and nuts.
3. Remove the fitting with the plastic cap (Fig. 1) from the port on the power unit and connect the hydraulic supply hose to the power unit using the supplied coupling (Fig. 2) (Teflon not required). Do not overtighten, backing nut & o-ring will complete the seal. **NOTE:** It may be necessary to remove the hydraulic hose from the 90° fitting and re-install in order to remove any twists in the hose.
4. Attach the lock release handle (Fig. 4) to the lower lock release post on the tow handle and tighten.
5. Route hydraulic hose through the clamp on the lift frame.
6. Fill the oil tank reservoir with hydraulic oil. To fill the oil tank reservoir, the lift must be completely lowered. Fill the oil tank with a premium quality ISO-32, AW-32, or AW-46 hydraulic oil.
7. Ensure all hydraulic fittings are tight and not leaking.

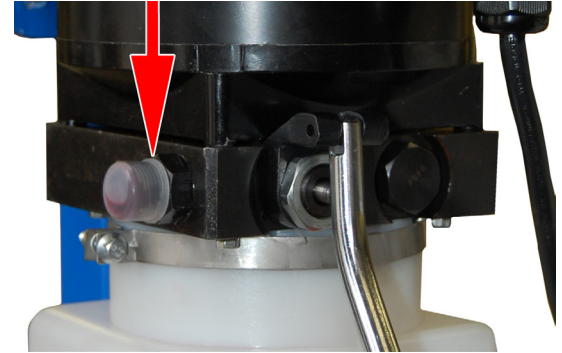

Fig. 1

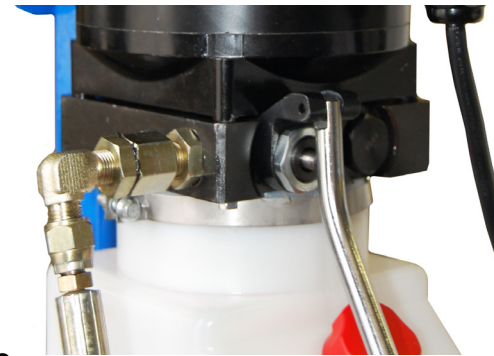

Fig. 2

5.2 LIFTING THE UNIT TO ATTACH THE LIFTING PLATES AND SADDLES

1. Clear the area of all bystanders, tools, equipment, and debris.
2. Plug the hydraulic unit into a standard 110V-120V/60Hz AC outlet.
3. Prior to raising the unit in order to proceed to section 5.3, please read section 6.

5.3 LIFTING PLATES, ADAPTERS & RUBBER SADDLE ATTACHMENT

Raise the unit to a comfortable working height by following all guidelines in section 6 and making sure the safety lock is engaged into the safety lock bar.

Attach the four(4) lifting plates to the lift by sliding the threaded pins through the sleeve brackets and attach using the four self locking nuts & washers.

Slide the plate adapter pedestals onto the lifting plates and secure with the four (4) hex bolts(62). **NOTE:** The adapters can be interchanged by sliding them on and off the lifting plates from the inside of the lift.

5.4 ELECTRICAL CONNECTIONS

 **WARNING: ALL WIRING CHANGES MUST BE PERFORMED BY A CERTIFIED LICENSED ELECTRICIAN. THE STANDARD ELECTRIC MOTOR USED ON YOUR LIFT REQUIRES A 110-120 VOLT, 60HZ, SINGLE PHASE HOOK-UP.**

 **WARNING: DO NOT PERFORM ANY MAINTENANCE OR INSTALLATION OF ANY COMPONENTS WITHOUT FIRST ENSURING THAT ELECTRICAL POWER HAS BEEN DISCONNECTED AT THE SOURCE OR PANEL AND CANNOT BE REENERGIZED UNTIL ALL MAINTENANCE AND/OR INSTALLATION PROCEDURES ARE COMPLETED.**

 **DANGER: DO NOT RUN POWER UNIT WITHOUT FLUID. DAMAGE TO PUMP CAN OCCUR. THE POWER UNIT MUST BE KEPT DRY. DAMAGE TO POWER UNIT CAUSED BY WATER OR OTHER LIQUIDS SUCH AS DETERGENTS, ACID ETC., IS NOT COVERED UNDER WARRANTY.**

6-OPERATION INSTRUCTIONS

 **WARNING: LIFT OPERATION BY TRAINED AUTHORIZED PERSONNEL OVER 18 YEARS ONLY. APPLY THE PARKING BRAKE AFTER POSITIONING THE VEHICLE ON THE LIFT. DO NOT ALLOW ANYONE TO STAY IN LIFT AREA DURING RAISING AND LOWERING CYCLES. CLOSELY WATCH THE VEHICLE AND THE LIFT DURING RAISING AND LOWERING CYCLES. OBSERVE THE RATED LOAD CAPACITY AND LOAD DISTRIBUTION. DO NOT ALLOW ANYONE TO CLIMB ON LIFT OR STAY INSIDE VEHICLE. AFTER RAISING THE VEHICLE FRAME 6”, STOP AND CHECK ADAPTERS FOR SECURE CONTACT. PERFORM BUMPER TEST. MAKE SURE THE VEHICLE DOORS ARE CLOSED DURING RAISING AND LOWERING CYCLES.**

6.1 DEFECTS / MALFUNCTIONS

 **WARNING: IN CASE OF DEFECTS OR MALFUNCTIONS SUCH AS JERKY LIFT MOVEMENT OR DEFORMATION OF THE SUPERSTRUCTURE, SUPPORT OR LOWER THE LIFT IMMEDIATELY. CONTACT QUALIFIED SERVICE PERSONNEL.**

6.2 CONTROLS

6.2.1 UP CONTROL

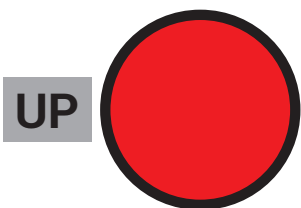

Once the up button is actuated, the lift moves up until the button is released or the limit stop is reached.

6.2.2 SAFETY LOCK CONTROL

Press and hold the lowering handle (Fig.3) until the safety lock (30) is engaged the safety lock bar (33).



Fig. 3

6.2.3 LOWERING CONTROL

Press the Up button enough to make the safety lock disengage the safety lock bar, squeeze the lock-release handle (Fig. 4), and then press the lowering handle (Fig.3) until the lift is completely lowered.



Fig. 4

6.3 OPERATION

⚠ WARNING: FAILURE TO OPERATE THE LIFT ACCORDING TO THIS MANUAL MAY CAUSE DAMAGE TO THE LIFT, PROPERTY DAMAGE AND/OR PERSONAL INJURY.

1. Before driving a vehicle over and onto the scissor lift make sure the lift is fully lowered, and position the plates and rubber saddles inward. Do not hit or run over the plates and rubber saddles, as this could damage the vehicle and/or lift.
2. Drive the vehicle over the lift while keeping the vehicle parallel with the lift and aligning the center of gravity of the vehicle with the center of the lift. **NOTE:** The “Center of Gravity” (COG) of the vehicle is the balance point at which there is equal weight in front of and behind the COG, and equal weight on both sides of the COG. The COG is not necessarily the dimensional center of the vehicle, but is often slightly toward the engine from the dimensional center of the vehicle.
3. Turn off the vehicle’s engine and engage the parking brake of the vehicle.
4. Read the vehicles owner’s manual to identify the recommended vehicle lifting points.
5. Prepare the work area according to this manual. Move the plates outward, and position the rubber saddles to contact with the vehicle manufacture’s recommended lifting points.

i IMPORTANT: PLACE THE FOUR RUBBER PADS UNDER EDGE OF VEHICLE AT THE FOUR JACK POINTS.

i IMPORTANT: FOR LOWER VEHICLES, IT MAY BE NECESSARY TO REMOVE THE HEX BOLTS(62) AND ALL ADAPTERS PRIOR TO DRIVING THE VEHICLE OVER THE LIFT AND SLIDE THEM ON AFTER THE VEHICLE IS OVER THE LIFT. BE SURE TO RE-INSTALL THE SAFETY HEX BOLTS PRIOR TO LIFTING THE VEHICLE.

6. Once the rubber saddles have been positioned under the vehicle lifting points, operate the power switch to make contact and lift the vehicle slightly. Test to make sure the vehicle is well balanced and the contact between the rubber saddles and vehicle lifting points are secure by performing the “BUMPER TEST.” (pg. 2) Then, proceed to lift the vehicle to the desired height.
7.  **WARNING:** Do not lift the vehicle if you cannot establish secure and level lifting points. Do not use sub-standard shims or other devices in place of approved and recommended rubber saddle adapters. Never use the lift without the rubber saddles in place on each plate and in contact with the lifting points of a vehicle.
8. Press up button and raise vehicle to desired height. Do not go under vehicle until load rests on level safety locks.
9. While lifting the vehicle a clicking sound should be noticeable which indicates the safety mechanism is operating. If this sound is not heard, immediately cease using the lift and call an authorized service agent.
10. When lift reaches maximum height, a limit switch will come into operation and stop the lift. When lift has stopped, press and hold the lowering handle (Fig. 3) until load rests on safety locks.
11. Once the repair work to the vehicle is complete, make sure to remove all tools, safety jack stands, and materials from under the vehicle and lift. Also, make sure the work area is clear and it is safe to lower the vehicle.
12. Lower vehicle by pressing the Up button to disengage the safety locks. Squeeze the lock-release handle (Fig. 4), and then press the lowering handle (Fig. 3) until the lift is completely lowered.
13. Move the rubber saddles and plates inward, out of the path of the vehicle. Clear all bystanders, and any objects from work area and direction of vehicle.
14. Disengage the vehicle parking brake. Start the vehicle’s engine, and drive the vehicle off the lift slowly and carefully.

 **WARNING: THE OPERATOR MUST BE TRAINED AND AUTHORIZED TO OPERATE THE LIFT.**

 **WARNING: DO NOT GO UNDER VEHICLE UNDER ANY CIRCUMSTANCES WHILE VEHICLE IS BEING RAISED OR LOWERED.**

 **WARNING: LOAD MUST BE EVENLY DISTRIBUTED BETWEEN BOTH LIFTING PLATFORMS. IF LOAD IS UNBALANCED, REPOSITION VEHICLE. DO NOT LOWER ON TO LOCKS AT DIFFERENT HEIGHTS.**

7-MAINTENANCE

 **WARNING: DISCONNECT THE POWER BEFORE SERVICING THE LIFT.**

 **IMPORTANT: THE MAINTENANCE INTERVALS INDICATED BELOW APPLY TO AVERAGE WORKSHOP USE. THE LIFT SHOULD BE INSPECTED MORE FREQUENTLY FOR SEVERE USE APPLICATIONS.**

7.1 MAINTENANCE SCHEDULE

It is important to keep the lift clean, dry, and well maintained by establishing a periodic preventive maintenance program to ensure trouble-free operation and long service life.

7.1.1 DAILY

1. Check safety locking mechanism is functioning correctly.
2. Inspect the condition of rubber lifting pads and replace as necessary if worn or torn.

7.1.2 MONTHLY

1. Check safety mechanism operation.
2. Check condition of shafts, shaft locks and bushings.
3. Check overall cleanliness.
4. Clean and lubricate roller slide tracks, rollers, and safety lock toggle shafts.

7.1.3 BIMONTHLY

1. Check condition of extensions and lubricate.
2. Check oil leaks from cylinders.
3. Check oil leaks at pipe joints.

7.1.4 YEARLY

Service and safety inspection on the lift must be performed by a competent person. This inspection must be recorded. If the 12 month service and safety inspection is not performed, the warranty is null and void.

 **IMPORTANT: YEARLY SERVICE MUST INCLUDE REMOVAL OF ROLLERS TO INSPECT, CLEAN AND LUBRICATE BUSHINGS AND PINS.**

7.1.5 EVERY OTHER YEAR

Hydraulic oil should be replaced.

7.2 MAINTENANCE BY OPERATOR

All moving parts have been lubricated at the factory and should be re-lubricated before the first use and at least once every six months to prevent damage.

7.2.1 HYDRAULIC SYSTEM (FIG. 5)

1. Check the fluid level with the lift fully lowered and add fluid as required. Use premium quality ISO-32, AW-32, or AW-46 hydraulic oil.
2. Check all hydraulic hoses and connections for tightness before each use to ensure proper working condition.
3. Lightly oil the cylinder rods at least once every six months or when they become dry.



Fig. 5

7.2.2 GREASING POINTS

The parts shown in Fig. 6 should be lubricated with lithium base grease.

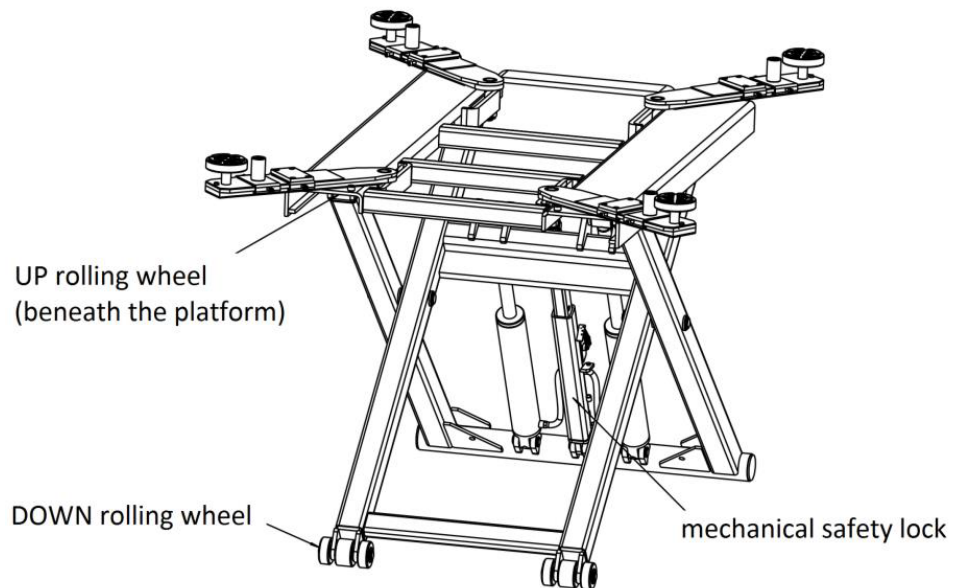

Fig. 6

7.2.3 OPERATION AND WEAR CHECKS

1. Examine lift for structural cracks, bends, or other signs of damage prior to each use. Do not use this product if worn or damaged.

7.2.4 LIFT STABILITY

1. Every six months check the nuts of all bolts for correct installation torque.
2. Retighten them as required. **NOTE: DO NOT USE AN IMPACT WRENCH.**

7.3 CLEANING



DANGER: DO NOT USE HIGH PRESSURE / STEAM JET CLEANERS OR CAUSTIC CLEANING AGENTS.

1. Periodically wash off aggressive substances and treat the lift with oil or wax spray.
2. Repair the damage to the paintwork immediately to prevent corrosion.

8-TROUBLESHOOTING

#	PROBLEM	CAUSES	REMEDY
1	Lift will not raise	The motor direction of rotation is not correct.	Interchange the two phases on the main switch
		The oil in the hydraulic unit is not sufficient.	Add some hydraulic oil
		The UP button is faulty.	Check UP button and connection for proper operation. Replace, if needed
		The maximum height limit switch is faulty.	Check the switch and relevant connection for proper operation. Replace, if needed.
		The lowering solenoid valve does not close.	Check and clean, if dirty, or replace, if faulty
		The suction pump filter is dirty.	Check and clean if needed.
2	Lift raise slowly	Not enough hydraulic oil	Supply oil
		The pressure of oil not sufficient	Adjust the pressure adjust screw
		Throttle valve not open	Open it
		Leakage in the oil circuit	Replace
3	Lift will not lower	No power	Power on
		Release valve dirty or clogged	Wash release valve in solvent and blow out with air
		Up/down valve damaged	Replace
		Air electromagnetic valve damage	Replace

9-DIAGRAMS

FIG. 1 - EXPLODED VIEW

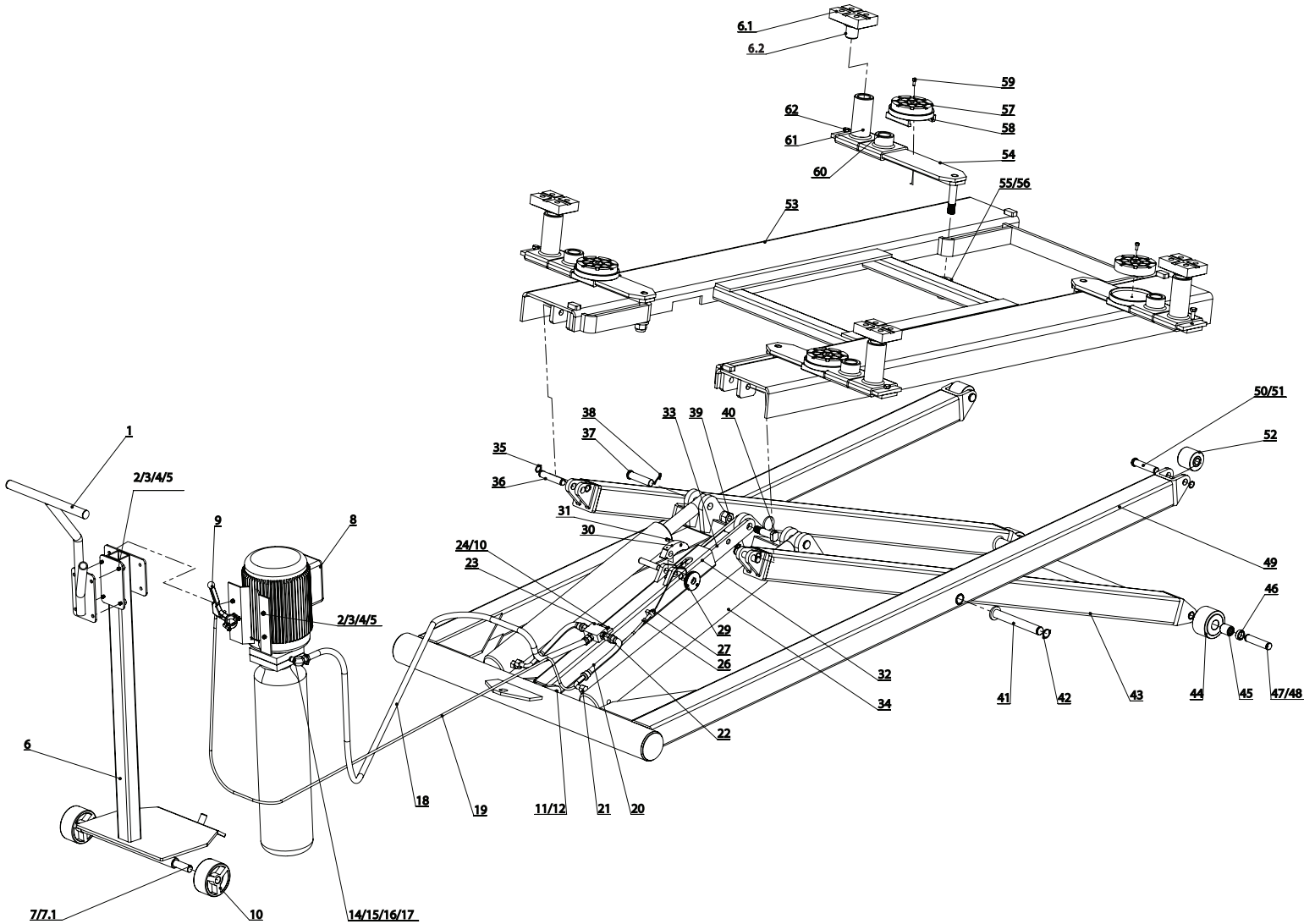

NO.	DESCRIPTION	QTY
1	Tow handle	1
2	Hex bolt	8
3	Flat washer	8
4	Spring washer	10
5	Hex nut	8
6	Power unit pedestal	1
6.1	Lifting Pad	4
6.2	Pad Mount	4
7	Flat washer	2
7.1	Cotter Pin	2
8	Hydraulic unit	1
9	Locking Release handle	1
10	Heavy-duty iron PU wheel	2
11	Spindle 3	1
12	Spindle retainer ring	2
14	Hydraulic fitting	1

NO.	DESCRIPTION	QTY
15	Washer	2
16	90°elbow fitting	1
17	Nut	2
18	Hydraulic supply hose	1
19	Locking release cable	1
20	Hydraulic hose	2
21	Valve	2
22	Straight connector	3
23	Tee oil-plate	1
24	Inner hex-head screw	2
26	Inner hex-head screw	1
27	Hex nut	1
29	Safety wheel and pin assembly	1
30	Safety lock	1
31	Tension spring	1
32	Safety tube	1
33	Safety lock bar	1
34	Cylinder	2
35	Spindle retainer ring	4
36	Spindle 9	2
37	Spindle 5	2
38	Cotter pin	2
39	Self-lock nut	1
40	Spindle 4	1
41	Spindle 2	2
42	Spindle retainer ring	2
43	Inner arm assembly	1
44	Roller 2	2
45	Punch bearing	2
46	Retainer ring	2
47	Spindle 1	2
48	Spindle retainer ring	2
49	Outer arm assembly	1
50	Spindle retainer ring	2
51	Spindle 6	2
52	Roller 1	2
53	Top cover plate	1
54	Lifting plate	4
55	Washer	4
56	Self-lock nut	4
57	Rubber pad	4
58	Flat Adapter	4
59	Inner hex-head screw	4
60	Short adapter	4
61	Long adapter	4
62	Hex bolt	4



LIMITED WARRANTY

The **Titan 2 Post lifts and 4 Post lifts** are backed by a standard **1 year** replacement parts warranty and a **5 year** structural warranty from the date of purchase, to the original purchaser only. The **1 year** replacement parts warranty covers power units, hydraulic cylinders, and all other assembly components such as, but not limited to: turn plates, slip plates, cables, chains, valves, switches etc. This does not cover normal wear items such as but not limited to rubber lifting pads and nylon slide blocks. Titan **HD2P-9000ACE-D** and **HD2P-9000AFE 2 Post lifts** are backed by a **2 year** replacement parts warranty and a **5 year** structural warranty from the date of purchase, to the original purchaser only. The **2 year** replacement parts warranty covers power units, hydraulic cylinders, and all other assembly components such as, but not limited to: turn plates, slip plates, cables, chains, valves, switches etc. This does not cover normal wear items such as but not limited to rubber lifting pads and nylon slide blocks.

Titan Mid Rise Scissor lifts are backed by a standard **1 year** replacement parts warranty and a **5 year** structural warranty from the date of purchase, to the original purchaser only. The **1 year** replacement parts warranty covers power units, hydraulic cylinders, and all other assembly components such as, but not limited to: turn plates, slip plates, cables, chains, valves, switches etc. This does not cover normal wear items such as but not limited to rubber lifting pads and nylon slide blocks.

Titan Standard Duty and Heavy Duty motorcycle lifts are backed by a standard **1 year** replacement parts warranty from the date of purchase, to the original purchaser only. The **1 year** replacement parts warranty covers power units, hydraulic cylinders, pneumatic cylinders, and all other assembly components such as, but not limited to: cables, caster wheels, valves, switches, wheel vises etc. This does not cover normal wear items such as but not limited to rubber wheel vise pads.

Titan Bulldog Moto Cradle Wheel Chock is warrantied for replacement parts, only to the original purchaser, for a period of **2 years** from the date of purchase.

XL Tool by Titan Wheel Service Machines and Helper Arm Assemblies are backed by a standard **1 year** replacement parts warranty from the date of purchase, to the original purchaser only. The **1 year** replacement parts warranty covers internal boards, motors, pneumatic cylinders, and all other assembly components such as, but not limited to: cabinet, switches, valves, fittings etc. This does not cover normal wear items such as but not limited to: rubber pads, jaw protectors, air hoses, quick nut assemblies.

Titan shop equipment products and accessories are warrantied for replacement parts only to the original purchaser for a period of **90 days** from the date of purchase. This **90 day** replacement parts warranty covers products such as but not limited to: EZ -Mover Jacks, Mini Jacks, tie down products, wheel service accessories, Bulldog Moto Cradle Wheel Chock accessories, dollies, stands, Light Duty Motorcycle Lifts, etc.

For **all** warranty considerations, Titan Marketing, LLC will supply replacement parts only during the warranty period. The original purchaser is responsible for all shipping, handling, and any labor charges incurred. All defective parts must be returned to Titan for inspection and examination. Any parts that are found to be defective will be replaced or repaired to proper working order. Other items not listed above may be considered general wear parts and therefore, will not be covered under warranty. These warranties **do not** extend to **defects** caused by ordinary wear, abuse, misuse, shipping damage, improper installation, voltage or lack of required maintenance. Titan Marketing, LLC is **not** to be held responsible for any **failure** that results from an accident, purchaser/operator abuse, neglect, or failure to operate products in accordance with instructions provided in the owner's manual(s) supplied. Damage caused by rain, excessive humidity, corrosive environments or other contaminants are not covered under warranty. **THESE WARRANTIES DO NOT EXTEND TO ANY COSMETIC DEFECT NOT INTERFERING WITH EQUIPMENT FUNCTIONALITY OR ANY INCIDENTAL, INDIRECT, OR CONSEQUENTIAL LOSS, DAMAGE, OR EXPENSE THAT MAY RESULT FROM ANY DEFECT, FAILURE OR MALFUNCTION OF A TITAN MARKETING LLC PRODUCT OR THE BREACH OR DELAY IN PERFORMANCE OF THE WARRANTY.**

WARRANTY REGISTRATION

In order to utilize the warranty on this Titan Lifts product, you must register your product with us. The simplest way to do this is to visit [TITANLIFTS.COM/WARRANTIES](https://www.titanlifts.com/warranties) and submit your information online. If you prefer to send your information through the mail, please fill out the form below and send this page to us at :

**Titan Lifts
PO Box 7069
Greenwood, IN 46142**

EQUIPMENT MODEL: _____ SERIAL NUMBER: _____
TYPE OF POWER UNIT: _____ SERIAL NUMBER: _____
DATE OF PURCHASE: _____
PLACE PURCHASED: _____
NAME: _____
STREET: _____
CITY, STATE, ZIP: _____
PHONE: _____
EMAIL: _____

OPT OUT OF PROMOTIONS



In order to receive your warranty, return this card or visit [TITANLIFTS.COM/WARRANTIES](https://www.titanlifts.com/warranties) within 30 days.

 **WARNING** 

The warnings, precautions and instructions in this manual cannot cover all possible conditions and situations that may occur. The operator must understand that the operator must supply common sense and examine caution factors when using this product to determine safety in all circumstances being used.



TITAN MARKETING, LLC

PO Box 7069 Greenwood, IN 46142
1.888.908-4826 FAX (317) 215.2770
www.titanlifts.com

**Patent No.: US 8,104,588 B2
CA 2,729,670**

Revision 12/11/17